



SP 650



**STONE SEPARATOR
SP650**



STONE SEPARATOR

Our stone separator removes all the heavy waste (stones, clods of earth, etc.) collected by the harvester. Its simple water-moving system uses a propeller that requires little energy compared with a traditional pump.

The mixing rate is around 160m³/h, which keeps the fruit in suspension. The water flow is regulated by an electronic variator. The fruit exits via a bar conveyor that drains it.

Heavy waste exits via a transverse belt.

Our separator works for all types of nuts, including chestnuts.

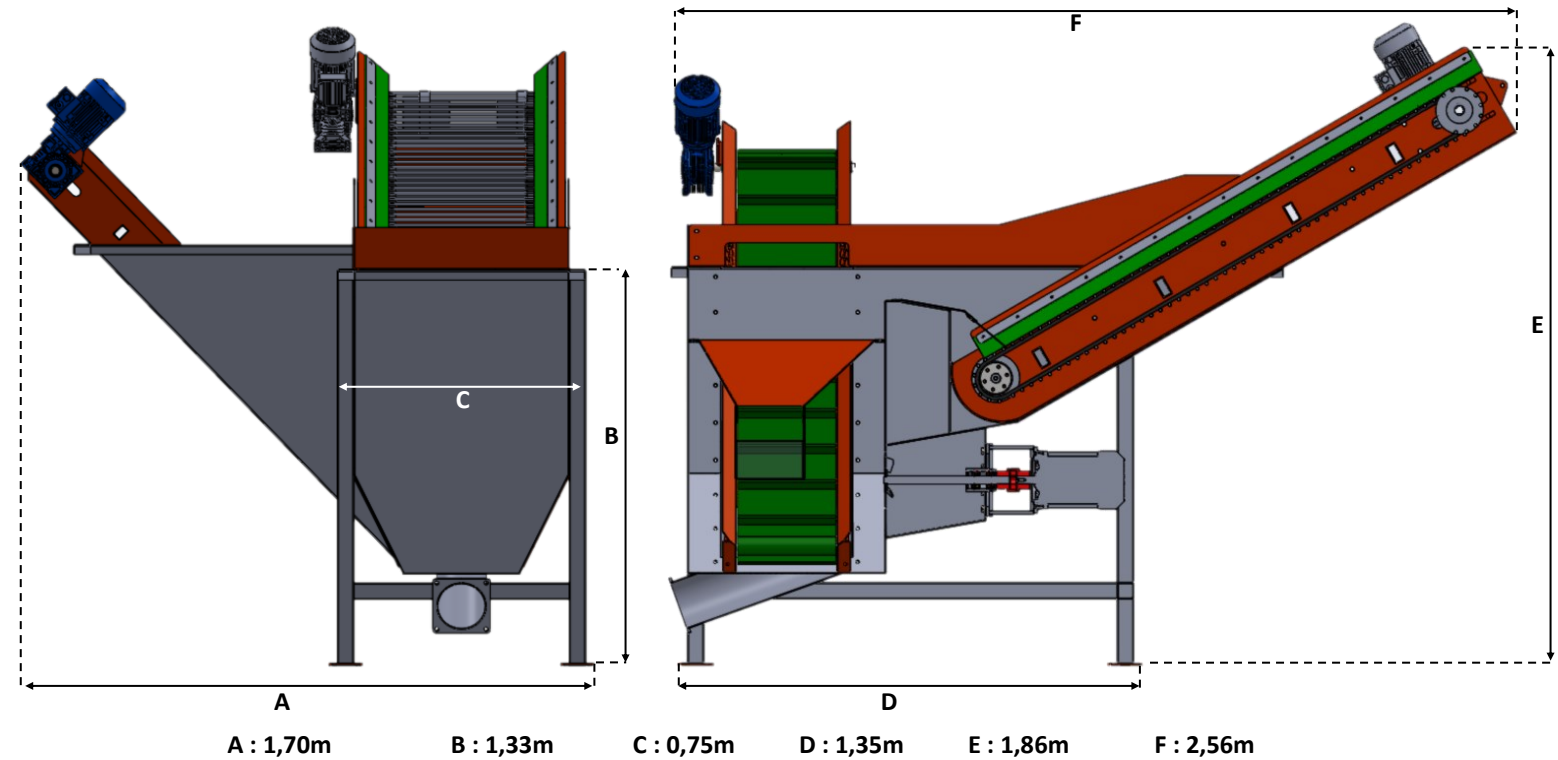

TECHNICAL CHARACTERISTICS



ELECTRIC BOX

MOTORISATION	Propeller motor: 2.2Kw Bar conveyor motor: 0.75Kw Stone conveyor motor: 0.37Kw Total power: 3.32Kw
PERFORMANCE	Up to 20m ³ /h
ADJUSTMENT WATER SPEED	Electronic variable speed drive
TANK CAPACITY	850L



04 56 33 74 54



contact@c2m-concept.com



597 Chemin de Montessut
38470 BEAULIEU



SAS C2M



@sas.c2m



SAS C2M

CONTACT